

# DUAL ADJUSTABLE TRIP OPTION ASSEMBLY

**46S02371-0061 SCHEMATIC 45S02371-0061**

DESCRIPTION

This option is one of a series available for Louis Allis Saber DC drives. It consists of components necessary for modifying the basic Controller for the adjustable trip function.

This option consists of two separate, but identical, electronically operated relay circuits. Either may be used alone, or the two may be used together. Each circuit can monitor one of six switch-selectable voltage signals. Five of these are DC voltage signals from the Controller 40-pin data bus:

1. Volt/Speed Comparator Reference
2. Scaled Tach Voltage
3. Uncalibrated Tach Voltage
4. Current Feedback (0-200% FLA)
5. Scaled Bridge Voltage

The sixth signal is an external DC voltage applied to terminals of the option assembly.

The gain is different for each input such that full adjustment sensitivity of pickup (relay energize) is available regardless of the input selected. Pickup can be adjusted for any voltage level within the range of the selected input. Dropout can be set for 50% to 100% of the pickup voltage level.

INSTALLATION

WARNING

REMOVE ALL INPUT POWER TO THE DRIVE BEFORE INSTALLING OPTION COMPONENTS.

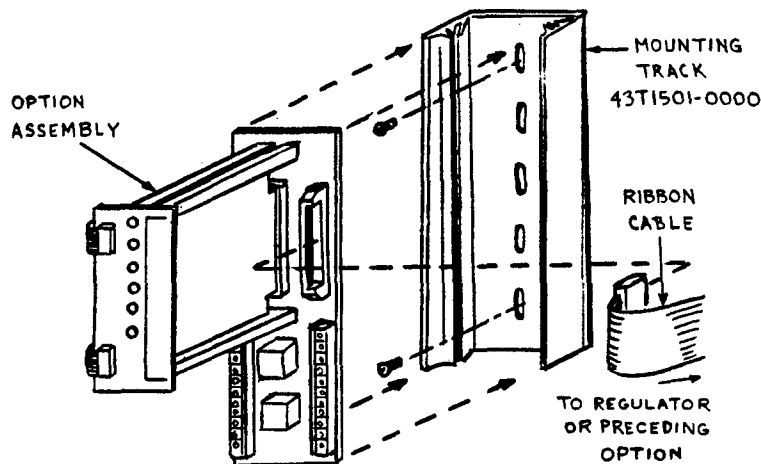

Figure 1.

**CHANGE RECORD**

1	STD-2718	3-17-81			
		REV			

DWG. NO. 02Y00025-0173  
 SHEET 1 OF 5  
 EFF. 7/31/83 (N)

See Figure 1. Install the option in the following manner:

1. Install PVC mounting track (L.A. part no. 43T1501-0000) to panel where option is to be mounted, using appropriate hardware.
2. Install option assembly by pressing firmly into mounting track.
3. Using 40 conductor ribbon, fabricate and install a double-ended ribbon cable of sufficient length to fit from 12CONN on the right side of the option to 12CONN on the Main PCB in the regulator power cube, or to 12CONN on the left side of a previously installed option.

Cable 12CONN provides the power and signal interface between this option and the Controller 40 pin data bus.

#### INTERCONNECTIONS

Set DIP switches 1SS-14SS on the Option Function PCB, according to the following chart, to select one voltage signal to be monitored by 1CR and/or one to be monitored by 2CR.

DWG. NO. 02Y00025-0173  
SHEET 2 OF 5  
EFF. 7/31/83 (N)

INPUT SIGNAL	SWITCHES SET TO ON		VOLTAGE RANGE
	FOR 1CR	FOR 2CR	
Volt/Speed Comparator Reference	1SS and 6SS	8SS and 13SS	0 to -10V (1)
	1SS and 7SS	8SS and 14SS	0 to -7.5V (2)
Scaled Tach Voltage	2SS	9SS	0 to +5V
Uncalibrated Tach Voltage	3SS	10SS	0 to +9V
Current Feedback	4SS	11SS	0 to +2V
Scaled Bridge Voltage	5SS	12SS	0 to +9V
External Voltage Signal			(3)

1) With 11SS on Volt/Speed Main PCB or 12SS (1) on Regulator PCB in Power Cube set to ON (normal applications).

2) With 11SS on Volt/Speed Main PCB or 12SS (1) on Regulator PCB in Power Cube set to OFF (only for special applications, when indicated by Louis Allis).

3) For external input in the range of 0 to 10.6V, no special setup is required. For external input with a maximum value greater than 10.6V, resistors must be installed on the Option I/O PCB in place of the jumpers at 81R and 82R (for 1CR) or 89R and 90R (for 2CR). These resistor pairs are to be 1/4W, 1%, with value in K ohms determined by the formula:

$$R = \frac{49.9 (V_{\max} - 10.6)}{10.6}$$

Connect external input to the Option I/O PCB at 1TB (1) (+) and 1TB (2) (-) for 1CR, or 2TB (17) (+) and 2TB (18) (-) for 2CR.

Drive Shutdown is the most common application for this option. Perform the following interconnections for drive shutdown.

1. Remove wire 25B from the Controller-to-OCS wiring (1TB (16) to STOP P.B.).

2. Use 18 gauge wire to make the required connections listed in the following chart and shown in Figure 2.

	FROM OPTION I/O PCB	TO	DIA-GRAM
For 1CR Trip Only	1TB (10) or (14)*	Controller, 1TB (16)	A
	1TB (9) or (13)*	OCS, Stop P.B.	
For 2CR Trip Only	2TB (26) or (30)**	Controller, 1TB (16)	A
	2TB (25) or (29)**	OCS, Stop P.B.	
For 1CR AND 2CR Trip	1TB (10) or (14)*	Controller, 1TB (16)	B
	2TB (26) or (30)**		
For 1CR OR 2CR Trip	1TB (9) or (13)*	OCS, Stop P.B.	C
	2TB (25) or (29)**		
For 1CR OR 2CR Trip	1TB (10) or (14)*	Controller, 1TB (16)	C
	1TB (9) or (13)*	2TB (26) or (30)**	
For 1CR OR 2CR Trip	1TB (9) or (13)*	2TB (26) or (30)**	C
	2TB (25) or (29)**	OCS, Stop P.B.	

Alternate connections (\* or \*\*) must be used in pairs.

For information on other applications, contact the Louis Allis Marketing Department. The relay contacts are rated to break 3A RMS at 115 VAC (resistive load).

DWG. NO. 02Y00025-0173  
SHEET 3 OF 5  
EFF. 7/31/83 (N)

Relay contacts are connected to the following terminals on the Option I/O PCB.

RELAY	N.O. CONTACTS	N.C. CONTACTS
1CR	1TB (10) & (11)	1TB (9) & (10)
	1TB (14) & (15)	1TB (13) & (14)
2CR	2TB (26) & (27)	2TB (25) & (26)
	2TB (30) & (31)	2TB (29) & (30)

#### ADJUSTMENTS

1. Turn PICKUP potentiometer (12RH for 1CR, 16RH for 2CR) fully clockwise. Turn DROPOUT potentiometer (11RH for 1CR, 15RH for 2CR) fully counterclockwise.
2. Start the drive. Rotate the SPEED control until the selected voltage signal is at the desired trip level.
3. Slowly rotate the PICKUP potentiometer counterclockwise until the relay energizes and its TRIP LED comes on.
4. The dropout relay is now set for 50% of the voltage level set in Step 2. Verify this by slowly rotating the SPEED control counterclockwise until the relay de-energizes (TRIP LED goes out), and note the level of the voltage signal.
5. If a higher dropout point is desired, first increase the SPEED

setting until the relay again energizes. Then rotate the SPEED control slowly counterclockwise until the voltage signal is at the desired dropout level. Slowly rotate the DROPOUT potentiometer clockwise until the relay de-energizes and the LED goes out.

6. If the option cannot be adjusted as indicated above, perform option troubleshooting procedures.

#### TROUBLESHOOTING

If other options have been installed, troubleshoot them thoroughly before discarding this assembly as faulty.

Troubleshooting consists of checking the operation of the electronically operated relay while the drive is running.

1. If either of the relays fails to energize during the adjustment procedure, run the drive at rated speed. Set both circuits to monitor the scaled bridge voltage signal, and rotate both 12RH and 16RH fully counterclockwise. If the relay still fails to energize, replace the Option Function PCB.
2. If either of the relays fails to de-energize during the adjustment procedure, replace both the Option Function PCB and the Option Adjust PCB.

#### OPTION RECORDS

After installation is completed, insert this instruction sheet immediately behind the front cover of the Controller instruction manual.

DWG. NO. 02Y00025-0173  
 SHEET 4 OF 5  
 EFF. 7/31/83 (N)

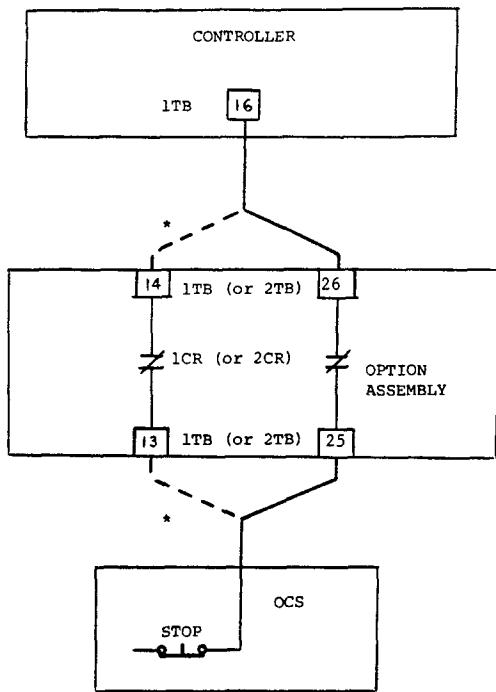

A. Motor to stop with trip of 1CR only or 2CR only

\*Dashed lines indicate alternate connections

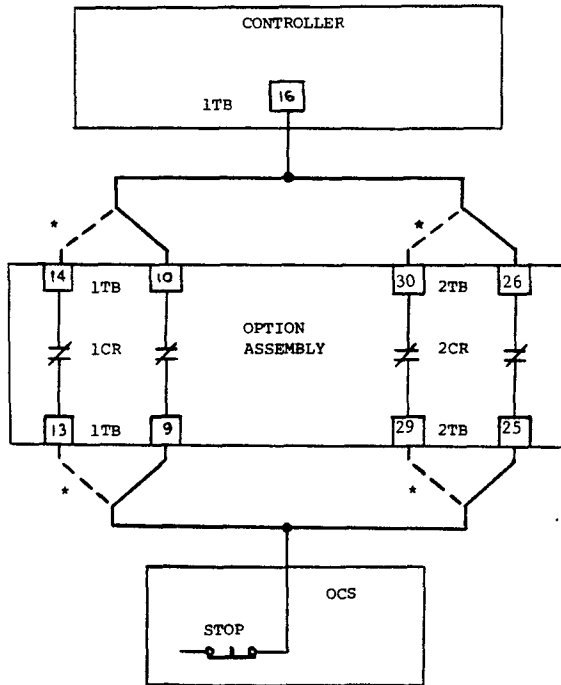

B. Motor to stop with trip of both 1CR and 2CR

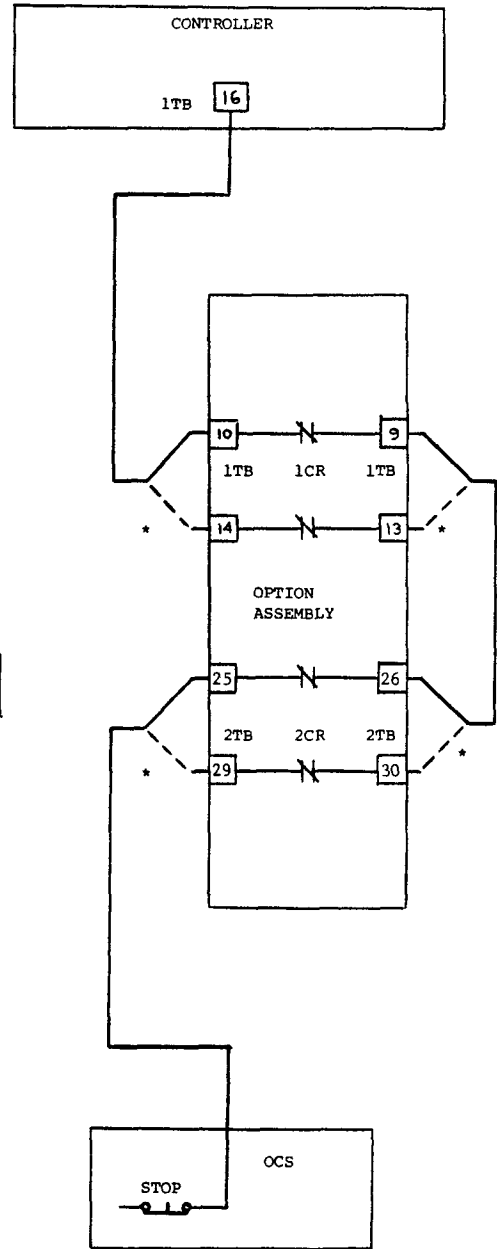

C. Motor to stop with trip of either 1CR or 2CR

Figure 2. Interconnections for Drive Shutdown

DWG. NO. 02Y00025-0173  
 SHEET 5 OF 5  
 EFF. 7/31/83 (N)

